

The Reaction $C_3H_3^+ + C_2H_2$ and the Structural Isomers of $C_5H_5^+$

Jikang Feng,[†] Jerzy Leszczynski, Brian Weiner,[‡] and Michael C. Zerner*

Contribution from the Quantum Theory Project, University of Florida, Gainesville, Florida 32611. Received November 3, 1988

Abstract: We study here the isomers of $C_5H_5^+$ and possible reactions between $C_3H_3^+$ and acetylene that lead to the formation of $C_5H_5^+$ using quantum chemical means. We find very many stable $C_5H_5^+$ isomers, the most stable being the vinylcyclopropenyl cation. A pyramidal form is calculated to be quite stable as are distorted planar cyclopentadienyl cations. Nonplanar distortions in these five-membered rings, however, do not appear stable. With an eye toward identification of these species in sooting flames and in Fourier transform ion cyclotron resonance experiments, we report the calculated vibrational and electronic spectra of these species. We also study reactions of $C_3H_3^+$ with acetylene, attempting to model the nucleation step in the formation of soot. We find that the cyclic form of $C_3H_3^+$ does not react with acetylene without sizeable barrier, whereas the linear propargyl cation reacts with acetylene without barrier to form many different $C_5H_5^+$ tautomers, some of which are quite stable. We discuss these findings in conjunction with the results of experiments on these systems.

Two mechanisms have been postulated to be of importance in the formation of soot in fuel-rich flames. One of these mechanisms involves small radicals in the particle inception (or nucleation) stage that eventually, through growth and chain-formation stages, form the chainlike particles composed of hundreds of thousands of carbon atoms that make up soot. The other mechanism involves small cations, rather than radicals, in the nucleation stage, and this mechanism is given credence especially with the observation of an abundance of small ions in sooting flames. It is the early states of this latter mechanism that we examine here.

The importance of understanding the mechanism of soot formation from the fundamental point of view is clear. A satisfactory solution to such longstanding problems as increasing fuel economy and reducing pollution during combustion reactions by interfering with the mechanisms of soot formation is hindered by our lack of such an understanding. Examining the chemistry of small ions is also made attractive by the fact that such reactions are now being studied in some detail in Fourier transform ion cyclotron resonance (FT-ICR) experiments that are designed to model flames.

The high concentration of $C_3H_3^+$ ions in sooting flames has suggested that this small cation is a principle precursor in the formation of soot.¹⁻¹¹ The reaction of $C_3H_3^+$ with small neutral hydrocarbons such as acetylene and diacetylene is then the postulated next step in this mechanism, followed by sequential condensation and condensation-elimination reactions, forming successively larger ions, and eventually yielding soot particles. Studies of ion/molecule reactions using FT-ICR techniques seem to indicate that $C_3H_3^+$ does form encounter complexes with acetylene, but under the conditions of the experiment no stable compounds are formed.¹² The reason postulated for this is that there is not enough time during the experiment for a further collision to carry away the excess kinetic energy that is preventing compound formation. By monitoring ion/molecule reactivity, however, it is apparent that there are two forms of $C_3H_3^+$ present in these experiments, only one of which is reactive.

With an eye to this mechanism of soot formation, we have previously examined the structures of possible $C_3H_3^+$ isomers and have characterized these species according to their relative energies and their vibrational and electronic spectra for possible identification in sooting flames.¹³ The reaction between $C_3H_3^+$ and C_2H_2 should yield then $C_5H_5^+$, or $C_3H_3^+$, or could yield starting materials back, with perhaps isomerization of the $C_3H_3^+$ ion:¹⁴

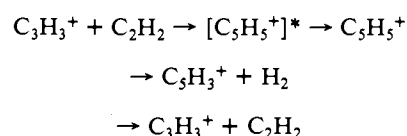

Within this work we examine the most stable structure of $C_5H_5^+$. We then examine possible reactions of $C_3H_3^+$ with acetylene, showing that many reactions can occur without barrier, as might be expected between a neutral molecule and an ion. Not all of these reactions lead to a product stable relative to the dissociation into acetylene and cyclopropenyl cation. Each of our most stable structures are then characterized according to their UV-visible spectra and their vibrational spectra for possible identification in experiments with sooting flames and in FT-ICR experiments on systems designed to model sooting flames.

There have been several studies in the past on $C_5H_5^+$ isomers. We will discuss these studies later but for the moment observe that these former studies have in many cases derived a different order of relative stabilities than those we report here.

Theoretical Methods

We first examine possible tautomeric structure of $C_5H_5^+$ using the INDO method,¹⁵⁻¹⁷ searching the potential energy surface with

- (1) Gaydon, A. G.; Wolfhard, H. G. *Flames, Their Structure, Radiation and Temperature*; Wiley: New York, 1979.
- (2) Miller, W. J. *Fourteenth Symposium on Combustion*; The Combustion Institute, 1973.
- (3) Calcote, H. F.; Kurzius, S. C.; Miller, W. J. *Tenth Symposium on Combustion*, The Combustion Institute, 1965.
- (4) Miller, W. J. *Oxidat. Combust. Rev.* **1968**, *3*, 98.
- (5) Tse, R. S.; Michaud, P.; Delfau, J. L. *Nature* **1978**, *153*.
- (6) Hayhurst, A. N.; Kittelson, D. B. *Combust. Flame* **1978**, *31*, 37.
- (7) Gooding, J. M.; Bohme, D. K.; Ng, C.-W. *Combust. Flame* **1979**, *36*, 27.
- (8) Olson, D. B.; Calcote, H. F. *Eighteenth Symposium on Combustion*, Combustion Institute, Pittsburgh, 1981; p 453.
- (9) Olson, D. B.; Calcote, H. F. In *Particulate Carbon: Formation During Combustion*; Siegl, D. C., Smith, G. W., Eds.; Plenum: New York, 1981; p 177.
- (10) Calcote, H. F. *Combust. Flame* **1981**, *42*, 215.
- (11) Harris, S. J.; Weiner, A. M. *Ann. Rev. Phys. Chem.* **1985**, *36*, 31.
- (12) Ozturk, F.; Baykut, G.; Moini, M.; Eyler, J. R. *J. Phys. Chem.* **1987**, *91*, 4360.
- (13) Leszczynski, J.; Weiner, B.; Zerner, M. C. *J. Phys. Chem.* **1989**, *93*, 139.
- (14) Wiseman, F.; Ozturk, F.; Eyler, J. R.; Zerner, M. C., manuscript in preparation.
- (15) Pople, J. A.; Beveridge, D. L.; Dobosh, P. *J. Chem. Phys.* **1967**, *47*, 2026.
- (16) Bacon, A. D.; Zerner, M. C. *Theor. Chim. Acta* **1979**, *53*, 21.
- (17) Anderson, W. P.; Edwards, W. D.; Zerner, M. C. *Inorg. Chem.* **1986**, *15*, 2728.

[†]Permanent address: Department of Chemistry, Jilin University, Republic of China.

[‡]Permanent address: Pennsylvania State University, Department of Physics, Dubois, PA 15801.

*To whom correspondence should be addressed.

Table I. Energies of Different Isomers of $C_5H_5^+$ (in hartrees)^a

Method	I	II	III	IV (triplet)	V	VI	VII	VIII	IX
STO-3G	-189.5968	-189.5614	-189.5724	-189.6333	-189.6011	-189.6006	-189.5542	-189.5542	-189.5600
3-21G	-190.8140	-190.7364	-190.7866	-189.8433	-189.8160	-190.8160 ^b	-190.8093	-190.8084	-190.8019
6-31G* 1Det GVB	-191.9183	-191.8652	-191.8828	-191.9334	-191.9024	-191.9021 ^b	-191.8801	-191.8828	-191.8744
6-31G**//6-31G*	-191.9278	-191.8757	-191.8924	-191.9426	-191.9117	-191.9309 ^b			
+MP2	-192.5468	-192.5263	-192.5124	-192.511	-192.5322	-191.9105	-191.8891	-191.8919	-191.8844
est rel energy, kcal/mol	0.00	12.9	21.6	~16.4	~9.2	~9.2 ^c	21.0	18.0	26.3

^aOne hartree equals 627.5 kcal/mol. See figures for the corresponding structures. ^bThis structure is a transition state leading to a distorted structure as given in Figure 6, which has an energy about 0.0002 hartree lower than the symmetric structure indicated in the figure. ^cWith a better calculation structure VI may be a transition state separating valence isomers of structure V; see text and footnote a.

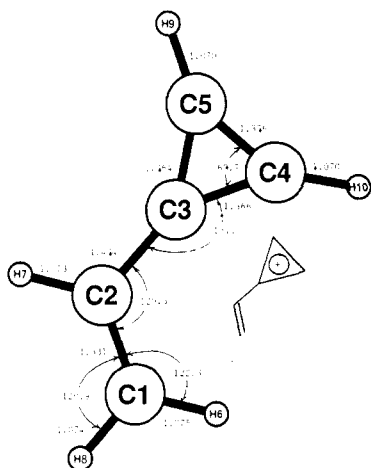

Figure 1. Structure I, vinylcyclopropenium cation. The geometry of this structure and all others is obtained from ab initio 6-31G* optimizations starting from structures with no symmetry by using gradient-driven structure determination methods unless otherwise stated; see text.

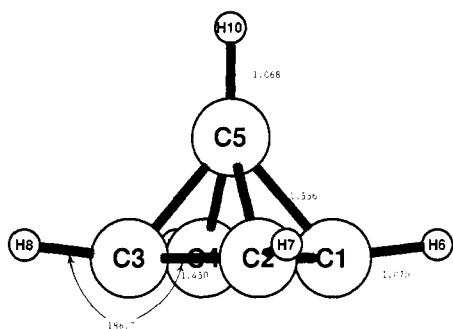

Figure 2. Structure II. See the caption of Figure 1.

a Broyden-Fletcher-Goldfarb-Shanno quasi-Newton update procedure.^{18,19} The uncovered structures are then refined by using the GAUSSIAN-86²⁰ and GAMESS²¹ ab initio programs, first with the STO-3G basis sets, then with 3-21G split-valence basis sets, and then with 6-31G* split-valence plus polarization basis sets.²² Vibrational frequencies are obtained by using the 3-21G basis at the geometry obtained for this basis. The correlation energy is estimated by utilizing a 6-31G** basis at the 6-31G* geometry and second order Møller-Plesset Rayleigh-Schrodinger perturbation theory (MP2/6-31G**//6-31G*) levels. The UV-visible spectra are calculated by using the INDO/S spectroscopic me-

(18) Head, J. D.; Zerner, M. C. *Chem. Phys. Lett.* **1985**, *122*, 264.

(19) Head, J. D.; Zerner, M. C. *Chem. Phys. Lett.* **1986**, *131*, 359.

(20) Binkley, J. S.; Frisch, M. J.; Defrees, D. J.; Raghavachari, K.; Whitesides, H. B.; Schlegel, H. B.; Fulder, E. M.; Pople, J. A. Carnegie-Mellon University, Pittsburgh, PA 15213.

(21) Dupuis, M.; Spangler, D.; Wendoloski, J. J. NRCC Program QC01 (1980). Dupuis, M.; Rys, J.; King, H. *HONDO QCPE 13* **1981**, *401*, 403. Guest, M.; Kendrick, J. Computational Science Group, Daresbury Lab. This version of the GAMESS program was obtained from Michael Schmidt, North Dakota State University.

(22) See, for example: Hehre, W. H.; Radom, L.; Schleyer, P. v. R.; Pople, J. A. *Ab Initio Molecular Orbital Theory*; Wiley: New York, 1986.

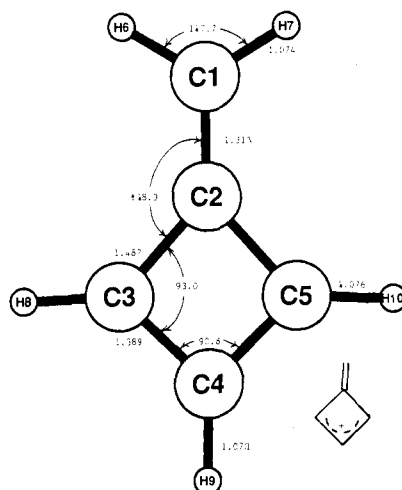

Figure 3. Structure III, methylenecyclobutenium cation. See the caption of Figure 1. This structure has C_{2v} symmetry.

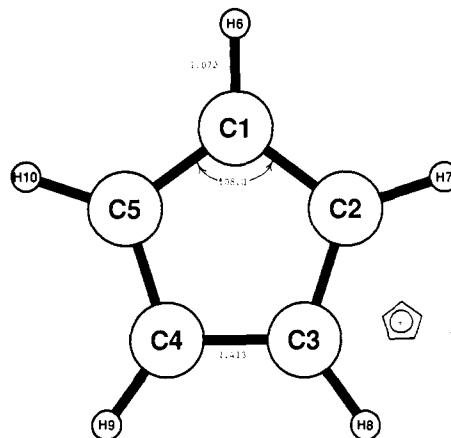

Figure 4. Structure IV. This is a triplet state of calculated D_{5h} symmetry; see text and the caption of Figure 1.

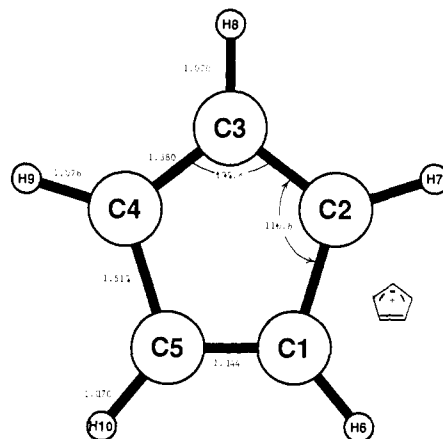
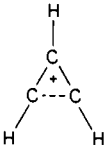

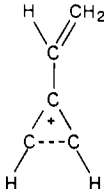

Figure 5. Structure V, singlet cyclopentadienium cation; see text and the caption of Figure 1. This structure has C_{2v} symmetry.

Table II

		+ 	→		+ ΔE
exptl, kcal/mol	256 ± 2	54.19			
<i>E</i> (SCF/3-21G), au	-114.3296	-76.3960		-190.8140	-0.0884
<i>E</i> (SCF/6-31G*), au	-115.0070	-76.8178		-191.9183	-0.0935
<i>E</i> (MP2/6-31G**/6-31G*), au	-115.3694	-77.0795		-192.5468	-0.0979
0.9 <i>E</i> (ZPE/3-21G), au	0.0438	0.0293		0.0813	0.0082
<i>E</i> (MP2/6-31G**/6-31G*) + 0.9 <i>E</i> (ZPE/3-21G)au	-115.3256	-77.0502		-192.4655	-0.0897
<i>S</i> , cal/(mol K)	54.4	47.1		69.7	-31.8

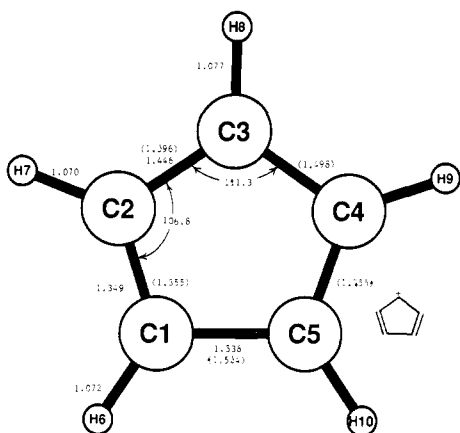

Figure 6. Structure VI. The numbers given in parentheses give rise to a structure that is lower in energy than the symmetrized coordinates reported by 0.0002 hartrees; see text. This structure has C_{2v} symmetry.

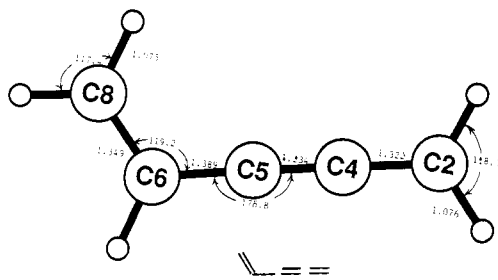

Figure 7. Structure VII, vinyl-substituted propargylium cation. See the caption of Figure 1.

thod^{23,24} at the optimized 6-31G* geometries. The oscillator strengths of the transition are estimated by using the dipole length operator and only one-center terms, as described elsewhere.²³ The INDO/S method has been found to be an accurate method for predicting electronic spectra, and this is especially so for positive species in which diffuse (Rydberg) states play only a minor role.¹³

Results

We initially examined some 21 possible structures uncovered from the INDO calculations and from suggestions reported in the literature. The nine most stable structures are reported in Table I, and their optimized geometries calculated at the 6-31G* level are reported in Figures 1–9. The best estimates of relative energies in this table we obtained from the MP2/6-31G**//6-31G* calculations. There is a difficulty here in comparing the open-shell structures of the cyclic species IV, V, and VI, with the closed-shell species and one that is not removed through the addition of second-order perturbation theory corrections. Rather, in a manner

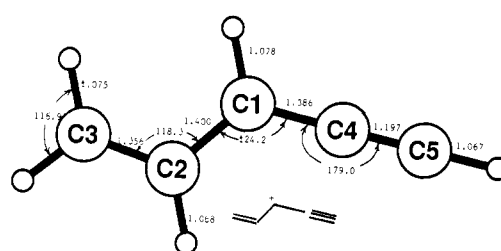

Figure 8. Structure VIII, ethynyl-substituted allyl cation. See the caption of Figure 1.

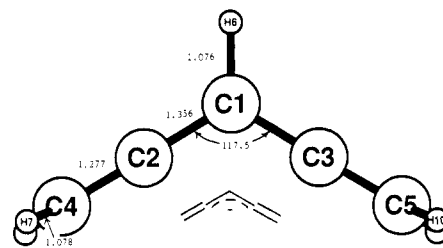

Figure 9. Structure IX, 1,3-dimethylenallyl cation. This is one of the few structures obtained that differed considerably from that obtained from the INDO studies. These latter calculations closed the C1–C2–C3 ring, a ring that the 6-31G* calculations opened. This structure has C_{2v} symmetry.

described subsequently, we believe that the triplet species is biased by about 0.03 hartree, or about 19 kcal/mol. This correction has been included in the estimates in this table, and it is consistent with results from the INDO spectroscopic values as described later.

Heats of formation of all of these species can be obtained from consideration of the reaction shown in Table II.

From the calculated ΔE of the reaction of -0.0897 hartree, or -56.3 kcal/mol, and the experimental heats of formation of the cyclopropenium cation^{25,26} and acetylene,²⁷ we estimate ΔE of formation of the vinylcyclopropenium cation, structure I, as 253.9 kcal/mol. Estimates for the other structures of this study can now be made utilizing the energy differences in Table I and the zero-point vibrational energies, $E(0)$ of Table III. We remark that contributions from the zero-point vibrational energy appear to make some difference in the energy of the reaction, reducing it by 5 kcal/mol. Assuming ideal gas relations, ΔH , the enthalpy of formation, can be estimated from

$$\Delta H = \Delta E - RT = \Delta E - 1.98 \times 10^{-3}T \text{ (kcal/mol)} \quad (1a)$$

and the Gibbs free energy of formation from

$$\Delta G = \Delta E - 1.98 \times 10^{-3}T - 3.18 \times 10^{-2}T = \Delta E - 0.0338T \text{ (kcal/mol)} \quad (1b)$$

The entropy of each species is estimated by using the Sakur–

(23) Ridley, J. E.; Zerner, M. C. *Theor. Chim. Acta* **1973**, *32*, 111.

(24) Zerner, M. C.; Loew, G. H.; Kirchner, R. F.; Mueller-Westerhoff, U. T. *J. Am. Chem. Soc.* **1980**, *102*, 589.

(25) Lossing, F. P. *Can. J. Chem.* **1972**, *50*, 3973.

(26) Holmes, J. L.; Lossing, F. P. *Can. J. Chem.* **1979**, *57*, 249.

(27) Benson, S. W.; Cruickshank, F. R.; Golden, D. M.; Huagen, G. R.; O'Neal, H. E.; Rogers, A. S.; Shaw, R.; Walsh, R. *Chem. Rev.* **1969**, *69*, 279.

Table III. Calculated Vibrational Frequencies by Using 3-21G Optimized Structures and Wave Functions (cm^{-1})

I	II	III	IV	V	VI ^b	VII	VIII	IX
167.1		150.7	505.3	255.6	254	167.8	154.1	155.9
251.6	247.4	358.9		360.2	360	198.4	195.4	274.7
412.1	553.9	425.1	794.4	469.0	445.9	365.4	40117	380.9
579.5	858.9	774.2	940.9	807.2	811.5	395.3	453.5	389.7
768.1		793.2		895.4	825.8	554.1	622.0	574.0
804.0		815.9	977.4	900.1	931.9	633.0	664.1	591.5
994.1	1002.4	954.1		935.5	933.7	833.1	898.0	672.2
1089.6	1003.5	1021.6	1006.1	1007.7	1005.3	846.5	1036.6	1015.8
1120.2		1070.6		1107.3	1070.6	1104.1	1038.8	1050.4
1129.8	1059.5	1104.9	1092.6	1129.8	1127.9	1181.3	1106.8	1075.5
1131.9	1152.9	1190.2		1158.6	1159.0	1212.8	1138.9	1106.8
1235.7	1155.3	1204.8	1290.8	1176.2	1178.2	1238.1	1211.1	1112.5
1245.9		1224.4	1297.7	1179.4	1213.5	1267.6	1271.0	1115.6
1335.9	1246.9	1257.8		1267.2	1268.6	1430.5	1359.2	1173.1
1466.4	1259.6	1306.0	1549.5	1355.0	1356.3	1469.9	1434.1	1490.6
1479.9	1295.4	1425.0		1429.4	1439.1	1582.0	1500.6	1522.0
1589.6	1316.7	1540.5	1566.7	1500.2	1475.0	1660.2	1642.6	1539.3
1777.3	1445.6	1610.3	1580.6	1581.4	1691.1	1721.8	1726.2	2041.0
1807.6		1911.6		1800.0	1715.9	2309.5	2308.8	2112.9
3331.7	3480.7	3331.9	3474.2	3404.1	3389.2	3298.6	3316.9	3274.4
3394.8	3489.1	3408.0		3404.7	3430.7	3332.6	3324.4	3279.1
3425.5		3410.0	3480.8	3447.6	3435.9	3380.7	3400.3	3345.3
3474.3	3509.2	3419.1		3465.7	3465.9	3395.9	3425.7	3360.6
3512.8	3585.9	3495.4	3688.8	3474.0	3472.0	3431.6	3594.0	3360.9
0.0903 ^a	0.0886 ^a	0.0848 ^a	0.0897 ^a	0.0855 ^a	0.0855 ^a	0.0843 ^a	0.0899 ^a	0.0873 ^a

^a $E(0)$ in hartrees. ^bThe asymmetric structure of Figure 6 has a negative frequency of -274 cm^{-1} , leading to the asymmetric structure of that figure.

Table IV. Calculated Electronic Spectra by Using the INDO-CI Spectroscopic Method for 6-31G* Optimized Geometries (1000 cm^{-1})^a

I singlets	II singlets	III singlets	IV triplets	V singlets	VI singlets	VII singlets	VIII singlets	IX singlets
43.1	61.7	18.5	28.6	10.0	7.6	15.7	22.6	23.0
(0.582)	(0.177)	(0.024)	(0.000)	(0.005)	(0.009)	(0.000)	(0.000)	(0.000)
50.3	61.7	38.4	28.6	25.3	22.1	34.6	33.1	27.9
(0.080)	(0.177)	(0.006)	(0.000)	(0.019)	(0.004)	(0.762)	(0.662)	(0.000)
50.4	71.1	44.3	33.7	40.5	41.1	42.9	4.6	42.3
(0.001)	(0.005)	(0.667)	(0.001)	(0.004)	(0.004)	(0.000)	(0.000)	(1.002)
55.4	71.1	48.8	33.7	45.9	43.7	46.4	46.6	48.6
(0.003)	(0.005)	(0.004)	(0.001)	(0.124)	(0.137)	(0.001)	(0.363)	(0.001)
57.2		49.6	49.0	49.0	48.2	46.5	47.8	53.6
(0.001)		(0.000)	(0.510)	(0.031)	(0.070)	(0.476)	(0.000)	(0.009)
58.3			49.0	51.9	51.3	54.0	53.3	53.7
(0.000)			(0.510)	(0.000)	(0.000)	(0.010)	(0.002)	(0.361)
59.6			49.7	52.3	51.7	54.1		
(0.000)			(0.004)	(0.000)	(0.000)	(0.002)		
			51.6	53.0	51.9			
			(0.000)	(0.000)	(0.007)			
			51.6					
			(0.000)					
I triplets	II triplets	III triplets	IV singlets	V triplets	VI triplets	VII triplets	VIII triplets	IX triplets
20.8	50.2	12.6	2.3	0.7	0.0	13.4	16.7	20.3
36.4	50.2	16.2	2.3	22.6	22.6	15.1	20.2	22.1
42.4	65.1	34.2	18.5	27.5	27.4	25.4	29.9	23.4
47.3	65.1	35.9	48.7	37.1	35.7	27.3	32.1	25.0
49.8		42.1	48.7	37.2	38.9	40.9	39.0	26.3
53.1			50.2	40.1	39.6	42.1	41.3	39.9
55.9			53.4	45.6	46.2	43.8		
			53.8	46.5	46.7			
				48.5	46.8			

^aThe numbers in parentheses are oscillator strengths.

Tetrode equation²⁸ and the calculated vibrational frequencies and moments of inertia.

The vibrational frequencies that we calculate for these low-lying species are reported in Table III, and they are unscaled. Multiplication by a factor of 0.90 usually gives quite satisfactory agreement with observed vibrational frequencies. We have also used this factor in our estimate of the heats of formation.

The calculated electronic spectra are reported in Table IV.

(28) See, for example: McQuarrie, D. *Statistical Mechanics*; Harper and Row: New York, 1976.

The calculation of the five-membered cyclic forms, structures IV, V, and VI, requires further comment. For the cyclic D_{5h} geometry, as with the triplet structure IV, the highest occupied orbitals are degenerate, π -like, and of e_{1g} symmetry. This then leads to six possible states:

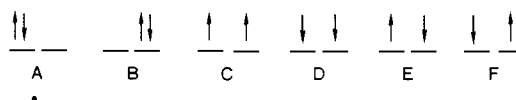

The triplet state, of ${}^3A_{2g}$ type, has components made from $\theta(C)$,

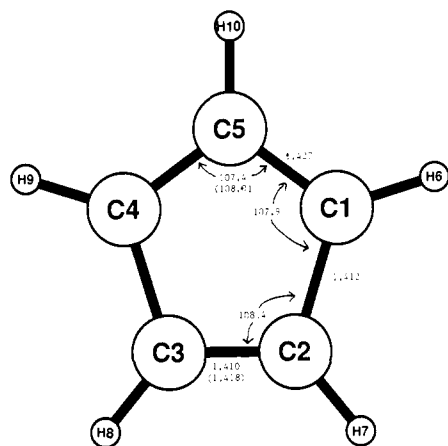
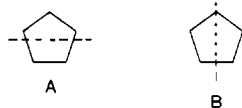

Figure 10. The cyclic $\alpha\beta\text{-}\beta\alpha$ singlet, or $(\theta(E) - \theta(F))$, structure as discussed in the text. These results are from INDO gradient-driven optimization calculations. The numbers given in parentheses give the calculated geometry of the triplet by the INDO method and are very close to those reported in Figure 4. The structure has C_{2v} symmetry.

$\theta(D)$, and $(\theta(E) + \theta(F))$. The 1E_g state has components $(\theta(E) - \theta(F))$ and $(\theta(A) + \theta(B))$ and is subject to a first-order Jahn-Teller distortion. The ${}^1A_{1g}$ state $(\theta(A) - \theta(B))$ lies considerably higher in energy. The triplet state has perfect D_{5h} symmetry as indicated in Figure 4. Structures V and VI as reported in Figures 5 and 6 can be understood as arising chiefly from $\theta(A)$ and $\theta(B)$ and the nodal structure of these orbitals:



The energies of these structures have been estimated from a two-determinant generalized valence bond (GVB) calculation. Structures V and VI, however, are each found to be dominated in these GVB calculations at their respective optimized geometries by $\theta(A)$ and $\theta(B)$, respectively. Since the second-order perturbation correction to the single-determinant energy (MP2) is in these two cases similar to that obtained for other singlet structures in Table I, our estimate of the relative energies for structure V is taken from the MP2/6-31G**//6-31G* calculations.

Of some considerable interest is the predicted structure arising from the GVB calculation which is principally $\theta(B)$. The geometry given in parentheses in Figure 6 lies some 0.0002 hartree lower in energy than the symmetric structure also given in this figure. This calculated distortion is also somewhat larger for the larger 6-31G* basis set (shown in the Figure) than it is for the 3-21G set, suggesting that this distortion is real and not an artifact of a Hartree-Fock instability. It is likely that a better calculation will show that the symmetric structure VI is a transition state between rotational isomers:²⁹

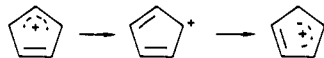

The $(\theta(E) - \theta(F))$ component of the 1E_g state also distorts and has the geometry as shown in Figure 10. This structure was obtained by the INDO procedure. Given for comparison in parentheses in this figure is the calculated INDO structure for the triplet, which is seen to be very similar to the triplet geometry obtained in the 6-31G* calculation summarized in Figure 4. The similarity in the calculated structures between all the INDO and ab initio procedures hopefully lends credence to the INDO-calculated geometry given in Figure 10. We are aware that INDO geometries can be considered only with some care, but we were not able to obtain the corresponding ab initio geometry for the

Table V Comparison of the Cyclic $C_5H_5^+$ Isomers^f

	triplet IV geom	singlet V ^d geometry	singlet VI ^d geom
triplet	UHF -191.9334 ROHF -191.9281 INDO [-]	-191.9128 ~191.908 [0.0033]	-191.9131 ~-191.908 [-0.0002]
$\alpha\beta\text{-}\beta\alpha^a$	ROHF -191.8911 INDO [0.0105]	-191.8682 [0.0451]	-191.8683 [0.0347]
singlet V ^b	ROHF GVB -191.9129 INDO [0.0105]	-191.9024 -191.9340 [-]	
singlet VI ^c	ROHF GVB INDO [0.0843 ¹ A _{1g}]		[0.1007] -191.9021 0191.9309 [-]

^a $(\theta(E) - \theta(F))$, see text. ^b $(\theta(A) + \theta(B))$ for the triplet geometry. For the optimized singlet geometries $\theta(A)$ or $\theta(B)$ dominates. ^c $(\theta(A) - \theta(B))$ for the triplet geometry ${}^1A_{1g}$. ^d Dominated by $\theta(A)$. ^e Dominated by $\theta(B)$. ^f Energies are in hartrees. Energies in brackets are INDO/S values relative to the energy of the reference geometry [-].

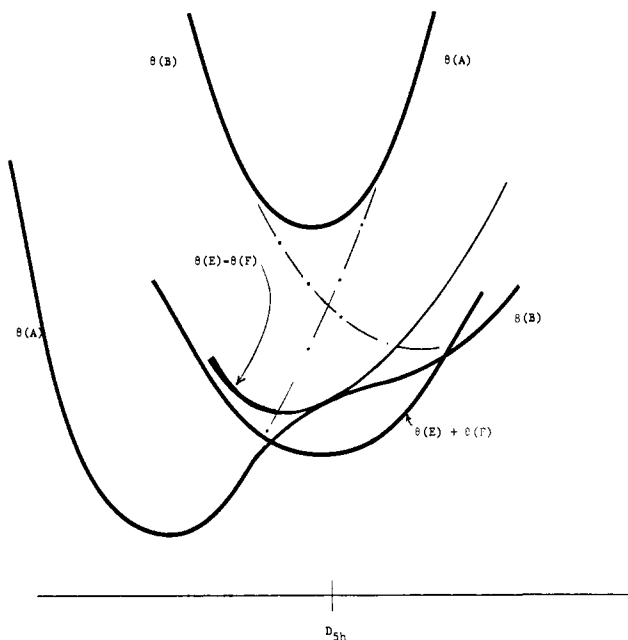

Figure 11. Schematic of the energy profile for the cyclic $C_5H_5^+$ structures. Only the minimum of each of the five structure has been examined in detail (see Table I) and the relative energies of each of these structures at these minima (see Table V).

$(\theta(E) - \theta(F))$ singlet with either the GAUSSIAN-86 or GAMESS programs.

Table V gives the energies of these four states at their individual optimized structures from calculations with the 6-31G* basis. These values are in reasonable accord with those obtained from the INDO spectroscopic configuration interaction calculations also reported as differences in the table. There are some important observations. All of these systems contain open shells. Systems with one open shell are often artificially favored in energy by about 0.03 hartree, and this can also be seen in this table when comparing GVB calculation that correlates the open-shell pair with the ROHF results given for the same structures. The INDO/CI results are parametrized in such a way as to not suffer from this defect. The INDO energy differences calculated at a given geometry are very similar to the ROHF ab initio energy differences at the optimized singlet structures V and VI. At the triplet geometry, which has D_{5h} symmetry, the $(\theta(A) + \theta(B))$ and $(\theta(E) - \theta(F))$ make up the two components of the 1E_g state. These two states are calculated degenerate by the INDO/CI model, but the ab initio SCF results have these states split by about 0.02 hartree. This is caused by the fact that one calculation is of necessity of the GVB type $(\theta(A) + \theta(B))$ and the other is open-shell ROHF. The INDO/CI results for this geometry are in reasonable good accord for the differences between the reference ROHF ab initio

(29) Clark, T.; Chandrasekhar, J.; Schleyer, P. v. R. *J. Chem. Soc., Chem. Commun.* 1980, 265.

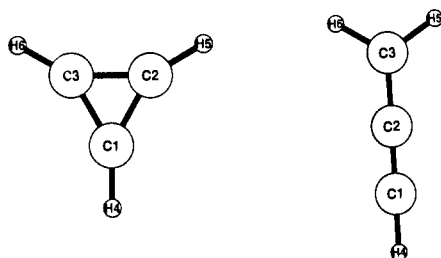

Figure 12. The two most stable $C_3H_3^+$ isomers: cyclopropenium cation, or $c-C_3H_3^+$, and the propargylium cation, $1-C_3H_3^+$; see ref 13.

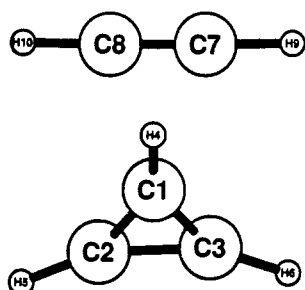

Figure 13. One of the weakly bonded complexes between $c-C_3H_3^+$ and acetylene, starting with a geometry in which the acetylene is above the $C_3H_3^+$ plane. The minimum for this structure is quite broad, and small changes in energy cause little change in energy.

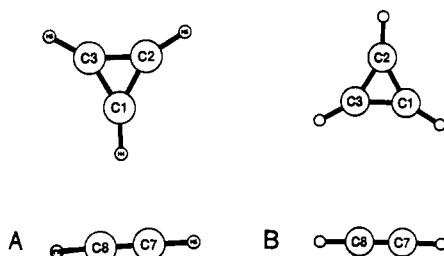

Figure 14. Two of the encounter complexes formed between acetylene and $c-C_3H_3^+$ when the two molecules have a starting geometry in the same plane. Both structures are stabilized by about 6 kcal/mol, and there is little cost in energy for any similar conformation.

triplet energy and that obtained for the GVB singlet. The situation is summarized schematically in Figure 11. We stress schematically, for only the point at the minimum of each state has been examined.

We conclude that of the structures we examine, structure I, vinylcyclopropenyl, is the most stable, followed by the singlet cyclopentadienyl ion, structure V. We estimate that the cyclic triplet structure IV is actually of higher energy than the cyclic singlet structure V on the basis of the facts (1) that the two-determinant GVB singlet is already of lower energy and (2) that the MP2/6-31G** energy favors the triplet by only 12 kcal/mol, not enough to compensate for the approximate 19 kcal/mol advantage given to the triplet by MP2 calculations. We note, however, that under the severe conditions met in flames these species as well as others might easily be formed, and we hope that our calculated spectra reported in Tables III and IV can be helpful in identifying their presence.

We examine the reaction of acetylene with the two most stable forms of $C_3H_3^+$,¹³ the cyclopropenyl cation and the propargylium cation, pictured in Figure 12. The cyclic form is calculated some 27.7 kcal/mol more stable than the linear form,¹³ in good agreement with the experimental estimate of 25 ± 4 kcal/mol.²⁵ The initial geometries we choose for the reaction of the cyclopropenyl cation with acetylene are similar to the final geometries we obtain, and these are given in Figure 13–14. In all of these cases there is no initial symmetry, other than perhaps a plane, as in Figure 14. When symmetry is obtained, it is obtained as a result of the geometry search. At the MP2/6-31G** level of theory these complexes are stabilized by about 6 kcal/mol. No

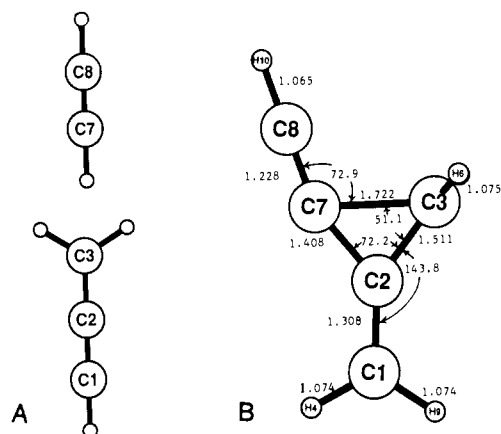

Figure 15. One of the reactions studied between $1-C_3H_3^+$ and acetylene. The starting geometry has only one plane of symmetry.

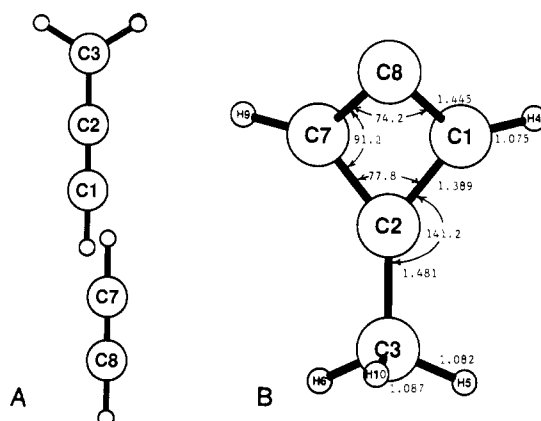

Figure 16. Second possible reaction of $1-C_3H_3^+$ with acetylene. The starting geometry has only one plane of symmetry. C8 is above the plane of C1–C2–C7–C3, H4 and H9 are below this plane. The 3–1–2–4 dihedral angle is 130.1° .

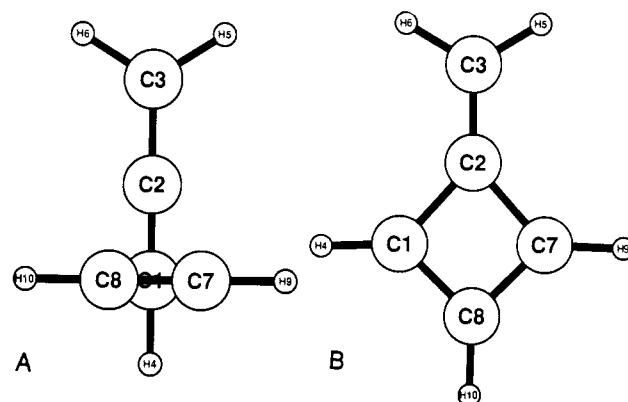

Figure 17. Third possible reaction of $1-C_3H_3^+$ with acetylene. The starting geometry has no symmetry. The structure obtained is the same as the structure shown in Figure 3.

attempt was made to correct this energy for basis set superposition, as it was not our intention to study such weak complexes. No further reaction occurs between acetylene and the cyclic isomer of $C_3H_3^+$ without sizeable barrier. In the few cases we sought a barrier, the ring opens to form the propargyl structure, and thus the barrier can be estimated to be greater than the difference between these two tautomers, that is, greater than 27.7 kcal/mol.

A similar study of this reaction is performed when the starting materials are the propargylium cation and acetylene, and this study is summarized in Figures 15–19. In each of these cases a reaction occurs without barrier to form the five products given in these figures. Figure 19 shows an intermediate step in the optimization, starting with the geometry indicated in Figure 19A.

Table VI. Calculated Energies of the Reaction Products $C_5H_5^{+a}$

theory	figure							
	13 ^b	14A ^b	14B ^b	15	16	17	18	19d
6-31G*	-191.8276	-191.8280	-191.8298	-191.8310	-191.8042	-191.8828	-191.8285	-191.8346
6-31G**	-191.8379	-191.8387	-191.8356	-191.8403	-191.8379	-191.8924	-191.8137	-191.8445
+MP2	-192.4559	-192.4584	-192.4521	-192.4844	-192.4588	-192.5124	-192.4323	-192.4787
$E_0(\text{vib})$				0.0828	0.0822	0.0848	0.0819	0.0809
$E(\text{est})^c$				-192.4099	-192.3848	-192.4361	-192.3586	-192.4059

^aNote: Energies are given in hartrees. Geometries are optimized with the 6-31G* basis sets unless otherwise states. ^bThese are very flat potentials. 13 and 14A are STO-3G geometries, 14B is a 6-31G* geometry. In the later case the 6-31G* optimization starting from the STO-3G geometry lowered the energy by 0.0043 hartree, a correction that might be added to the energies of 13 and 14A. ^c $E(\text{MP2}/6-31G^{**}/6-31G^*) + 0.9E_0(\text{vib})$.

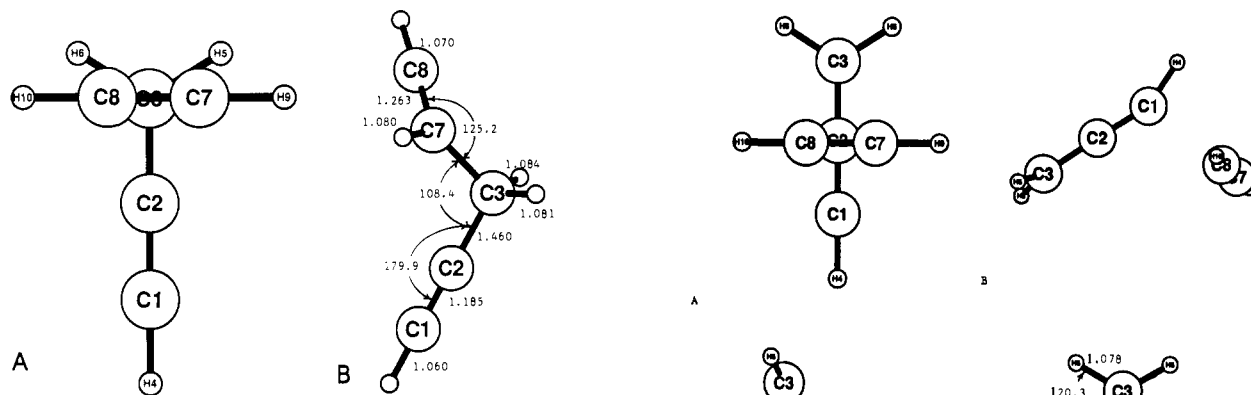
**Figure 18.** Fourth possible reaction of $1-C_3H_3^+$ with acetylene. The starting geometry has no symmetry.

The relative energies of these new $C_5H_5^+$ structures are given in Table VI. The structure of Figure 17, right, is identical with that given in Figure 3. To ensure that each of these systems represents a true minimum of the potential energy surface, their vibrational frequencies were calculated, and they are given in Table VII. Some of these calculated frequencies are very low, and they are likely to become even lower (see ref 13) with better basis sets and with the inclusion of correlation in the calculation. Considering the excess energy available in these systems, either through ion formation in the FT-ICR experiments or in actual flame situations, these species might undergo rearrangements.

Discussion

The nine most stable $C_5H_5^+$ structures that we have examined are given in Table I. Several of these species have been examined previously.³⁰⁻³⁴ Dewar and Haddon suggested bent cyclic structures



might be most favored on the basis of MINDO/3 calculations.³³ We attempted geometry optimization starting with their bent geometries, but in each case the resulting optimization led to the planar forms of structures V or VI. This out-of-plane distortion, however, is of little cost in energy.

Much speculation has focused on the stability of the pyramidal form of $C_5H_5^+$, structure II, postulated to lie lowest on the surface by Stohrer and Hoffman some time ago.³² Although this is most certainly a stable structure, as indicated by the reported force field of Table III, we estimate this structure to lie 12.9 kcal/mol higher in energy than structure I. This is a value similar to that reported by Kohler and Lischka,³⁴ but an estimate of theirs using the CEPA method predicts the square-based pyramid lower than the cyclic form by 24 kcal/mol. Although the differential correlation energy does seem to favor structure II more than structure IV, with MP2

Figure 19. Fifth possible reaction of $1-C_3H_3^+$ with acetylene. The starting geometry has no symmetry. The second frame B is a structure obtained during the course of the reaction and does not represent a separate minimum. The final structure is given in frames C and D and has one plane of symmetry.**Table VII.** Calculated Vibrational Frequencies of the Reaction Products by Using 3-21G Optimized Structures and Wave Functions (cm^{-1})

Figure 15B	Figure 16B	Figure 18B	Figure 19D
169.4	73.2	104.5	135.0
291.2	293.5	237.8	231.3
305.7	364.8	270.7	335.9
467.6	519.9	419.3	517.1
475.5	665.3	542.0	532.5
765.5	699.8	747.6	560.7
818.2	860.1	759.6	733.0
834.2	1006.4	888.0	869.9
908.3	1010.5	959.3	922.4
986.7	1151.1	977.6	985.9
1023.7	1165.2	996.6	1043.1
1148.3	1204.3	1047.3	1089.2
1206.6	1243.7	1125.0	1115.4
1243.3	1322.0	1240.3	1125.3
1256.3	1390.5	1367.9	1159.7
1579.0	1566.0	1457.5	1427.1
1616.0	1619.8	1616.3	1534.3
1914.8	1624.1	1836.0	1947.1
2249.6	1651.6	2415.6	2106.3
3297.6	3187.9	3243.7	3285.0
3345.7	3261.8	3271.6	3368.4
3425.1	3309.4	3309.3	3409.3
3440.3	3440.0	3482.6	3500.9
3579.6	3448.2	3638.6	3586.2

(30) Kollmar, H.; Smith, H. O.; Schleyer, P. v. R. *J. Am. Chem. Soc.* **1973**, *95*, 5834.

(31) Hehre, W. J.; Schleyer, P. v. R. *J. Am. Chem. Soc.* **1973**, *95*, 5837.

(32) Stohrer, W. D.; Hoffman, R. *J. Am. Chem. Soc.* **1972**, *94*, 1661.

(33) Dewar, M. J.; Haddon, R. C. *J. Am. Chem. Soc.* **1973**, *95*, 5836.

(34) Kohler, H.-J.; Lischka, H. *J. Am. Chem. Soc.* **1979**, *101*, 7863.

this is only by 19 kcal/mol. The pyramidal form is not our lowest energy form. We note, however, that the relative energy of this

structure is most sensitive to the basis set quality. Experimentally this form has been reported to exist in solution.^{35,36}

Experimental values of the heat of formation of $C_5H_5^+$ have been obtained from mass spectroscopic methods, and these values vary from 239 to 309 kcal/mol. These values differ for experimental reasons, but they are also likely³⁷⁻⁴³ dependent on the source and on the means of ion production, and different isomers might have been produced in the different experiments. Subsequent ICR experiments, for example, seem to indicate that at least four stable species of $C_5H_5^+$ are easily made.^{44,45} Our value of ΔE of 254 kcal/mol for our most stable species is in reasonable accord with the lowest value in the experimental range, but we do not believe it is wrong by 15 kcal/mol. The 70 kcal/mol range of experimental values, in addition, more than spans our most reasonable structures, suggesting either errors in the experiments or that unusual species, such as some of those reported in Table VI, are formed in the ion preparation.

Experimentally, propargyl iodide can be dissociated into the propargylium cation and iodine in FT-ICR experiments. Upon collision with acetylene and deuterioacetylene, a complex is formed with a long enough lifetime to scramble the deuterium. This reaction has been kinetically modeled,¹⁴ and it is apparent that in the absence of three-body collisions, such $C_5H_5^+$ complexes are short lived, yielding two forms of $C_3H_3^+$, one that can further react to again form stable associations, again scrambling deuterium, and one that is unreactive. These calculations suggest that the cyclic isomer ($c-C_3H_3^+$) is the stable species. The encounter complex is formed, however, with considerable excess internal energy, thus explaining the lack of any $C_5H_5^+$ stable structures in the FT-ICR experiments. These same experiments carried out with diacetylene do lead to stable structures of formulas $C_7H_7^+$, $C_7H_5^+$, $C_9H_5^+$, and $C_9H_7^+$. Even so, models of this reaction also require collisional deactivation of the appropriate species to carry away the excess internal energies before the complexes can fractionate.

We have examined five different approaches of C_2H_2 to the propargylium cation ($1-C_3H_3^+$), two in-plane and three out-of-plane, as shown in Figures 15-19.⁴⁶ The two resonance structures of this isomer

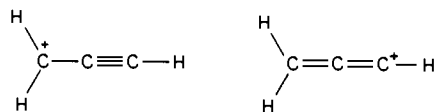

(35) Saunders, M.; Berger, R.; Jaffe, A.; McBride, J. M.; O'Neill, J.; Breslow, R.; Hoffman, J. M., Jr.; Perchonok, C.; Wasserman, E.; Hutton, R. S.; Kuck, V. J. *J. Am. Chem. Soc.* **1973**, *95*, 3017.

(36) Masamune, S.; Sakai, M.; Ona, H. *J. Am. Chem. Soc.* **1972**, *94*, 8955. Masamune, S.; Sakai, M.; Ona, H.; Jones, A. J. *Ibid.* **1972**, *94*, 8956.

(37) Occolowitz, J. L.; White, G. L. *Aust. J. Chem.* **1968**, *21*, 997.

(38) Harrison, A. H.; Haynes, P.; McLean, S.; Meyer, F. J. *Am. Chem. Soc.* **1965**, *87*, 5099.

(39) Franklin, J. L.; Carroll, S. R. *J. Am. Chem. Soc.* **1969**, *91*, 6564.

(40) Tajima, S.; Tsuchiya, T. *Bull. Chem. Soc. Jpn.* **1973**, *46*, 3291.

(41) Lossing, F. P.; Traeger, J. C. *J. Am. Chem. Soc.* **1975**, *97*, 1579.

(42) McCreary, D. A.; Freiser, B. S. *J. Am. Chem. Soc.* **1978**, *100*, 2902.

(43) Dorman, F. H. *J. Chem. Phys.* **1965**, *43*, 3507.

(44) Buckley, T. J. Ph.D. Thesis, University of Florida, Gainesville, FL, 1982.

(45) Brill, F. W. Ph.D. Thesis, University of Florida, Gainesville, FL, 1983.

(46) Leszczynski, J.; Wiseman, F.; Zerner, M. C. *Int. J. Quantum Chem.*, in press.

suggest attack of the electron-rich acetylene to the end carbons, and this is what we find. The final structures are reported in the figures, their energies are reported in Table V, and their calculated frequencies are reported in Table VII.

The energy calculated for the cyclopropenylum cation and acetylene at the MP2/6-31G**//6-31G* level of theory is -115.3694 and -77.0795 hartrees, respectively. Correcting these values by scaling the calculated zero-point vibrational energy by 0.9 as we did previously yields estimated internal energies of -115.3256 and -77.0502 hartrees, respectively.¹³ Using these values suggests that only systems of lesser total energy than -192.3758 hartrees will be thermodynamically stable relative to dissociation back into acetylene and cyclic $C_3H_3^+$, if we ignore entropy effects. Estimating the entropy²⁸ and recalling the loss of 1 mol of gas, we can estimate the free energy of this reaction as

$$\Delta G = E(\text{calcd}) + 0.9E(\text{vib}) - 192.3758 + 5.4 \times 10^{-5}T$$

where the $E(\text{calcd})$ is at the MP2/6-31G** level of theory, and T is the temperature in kelvin. According to this estimate, at $T = 0$ K, all of the $C_5H_5^+$ structures we have examined are thermodynamically stable relative to

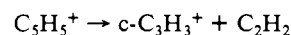

except that of Figure 18, right. At temperatures in flames, however, say 1000 K, only the reaction shown in Figure 17 leads directly to a thermodynamically stable species. Considering the excess energy available in flames, however, low-lying barriers to isomerization might be traversed from the initial structures listed in Figures 13-19 to the more stable structures of Table I. Further collisions might then lead to loss of kinetic energy and stabilization of the $C_5H_5^+$ species before decomposition back into $C_3H_3^+$ and acetylene or even directly into compounds of higher carbon content.

We have examined here the isomers of $C_5H_5^+$ and simple reactions in which this ion can be formed from acetylene and $C_3H_3^+$, species abundant in fuel-rich flames. Other reactions are possible, but it seems unlikely that ionic precursors of soot do not involve $C_3H_3^+$. Recently, however, reactions between $C_3H_3^+$ and diacetylene have been examined in the FT-ICR models of flames, and these reactions readily lead to higher molecular mass ions.^{12,14,47} This reaction might, indeed, be more important in the actual mechanism of soot formation than that which we have studied here. We have begun to examine these reactions also, but the greater number of atoms involved makes theoretical study that much more costly.

Acknowledgment. These studies were supported in part through a grant from the Environics Division of the United States Air Force Engineering and Services Center, Tyndall, AFB, FL. Many of these computations were performed at the Pittsburgh Supercomputer Center and at the Florida State University Cyber 205 Supercomputer Center. We gratefully acknowledge discussions with Dr. John Eyler, University of Florida, and with Captain Floyd Wiseman, Tyndall Air Force Base.

(47) Eyler, J. R., work in progress.